

FLOOR DRAIN INSTALLATION INSTRUCTIONS

Installation is to comply with AS/NZS 3500.1 and AS/NZS 3500.2 Standards.
Any inconsistencies or doubts about the quality of the seal should be inspected by a certified plumber.

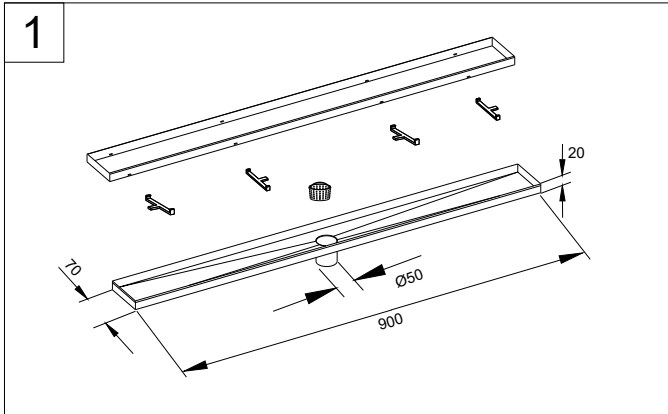

1. Confirm the size of the floor drain installation seat (length, width, depth) and the position of the product drain outlet.

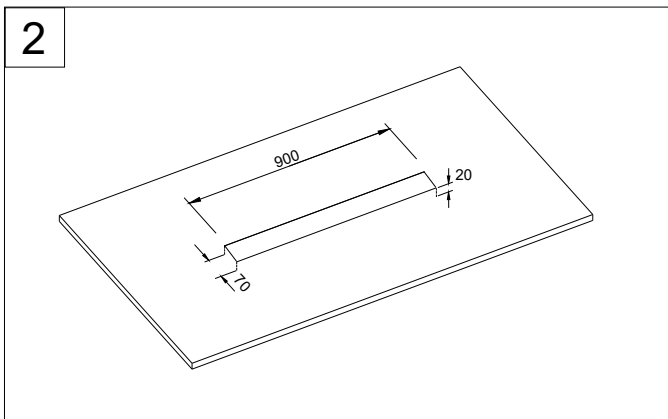

2. Dig a groove at the installation location and confirm that the installation groove is sufficient to install the product.

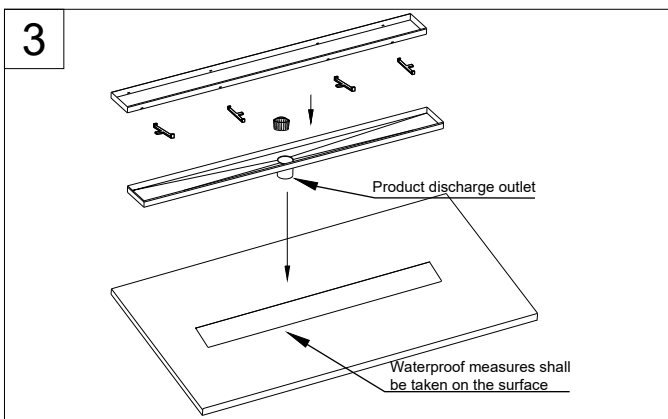

3. Place the product into the installation groove in the order of product installation. Waterproof measures shall be taken on the surface. Ensure that the size of the drain outlet in the groove is larger than the size of the product drain.

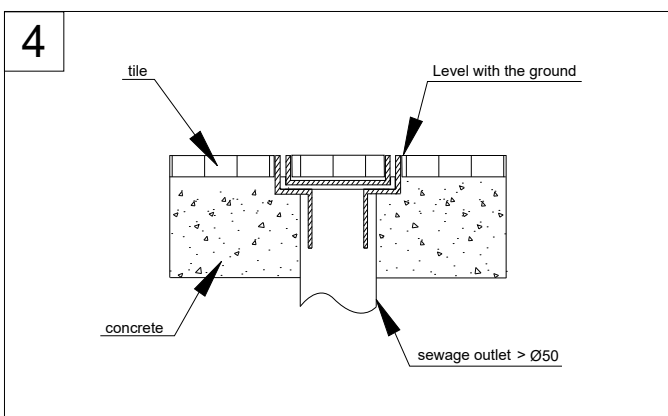

4. After installation is completed, confirm that the product plane is flush with the ground. Confirm that the product is clean and tidy, with unobstructed drainage